



### Exceptional productivity:

- Working height up to 13.8m
- Driveable at full height
- Load capacity: 350 kg
- Extended platform
- High Operating Autonomy
- Robust, reliable, easy to maintain

### Optimum compactness

- 1.2m width
- Folding guardrails

350 kg / 3x  
770 lbs

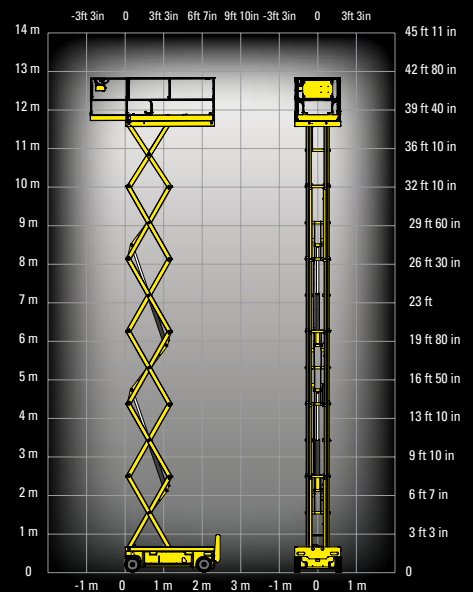

**Haulotte**  
GROUP

Experience in innovation



# COMPACT14

## ELECTRIC SCISSOR LIFTS

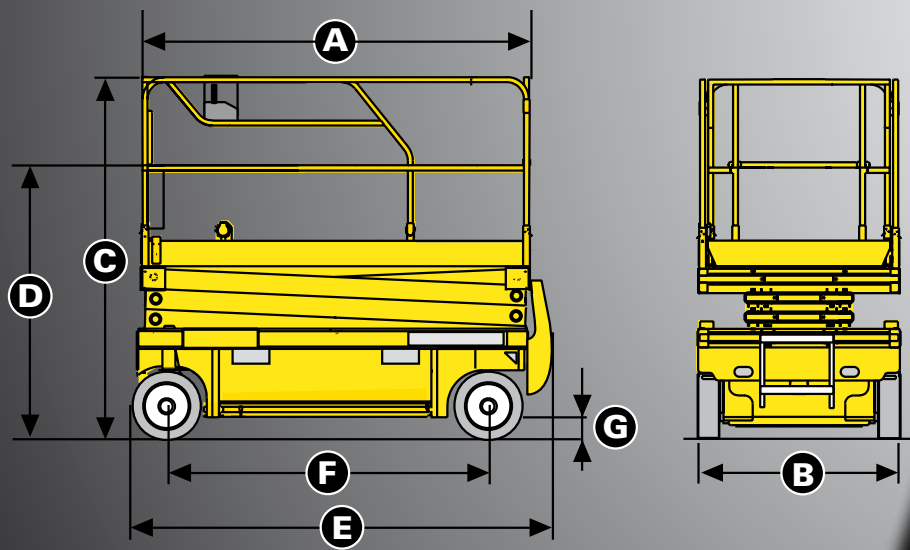

### TECHNICAL DATA

### COMPACT 14

Working height	13.8 m
Platform height	11.8 m
Lift capacity	350 kg
A - Platform length - outside	2.3 m
Platform length - extended	3.22 m
Length - extension	0.92 m
B - Platform width - outside	1.2 m
C - Height - stowed	2.5 m
D - Storage height	2.08 m
E - Length	2.45 m
B - Overall width	1.2 m
F - Wheelbase	1.86 m
G - Ground clearance - Centre	13 cm
Ground clearance - Pothole guards deployed	2.3 cm
Drive speed	0.9 - 2.8 km/h
Driveable at full height up to	11.8 m
Gradeability	23 %
Tilt	2° / 3°
Lift / lower speed	66 s / 54 s
Turning radius - outside	2.38 m
Tyres - non marking	15x5
Batteries	24 V - 255 Amph (C5)
Hydraulic system capacity	25 l
Weight	3170 kg

### STANDARD EQUIPMENT

- Pothole guards
- Battery charge indicator
- Proportional lift and drive
- Removable control box in platform
- Swing out component tray
- Battery charger with automatic stop
- Solid non-marking tyres
- Brake release
- Tilt controller
- Load Management System in the platform
- Manual platform lowering valve
- Integrated forklift pockets
- Towing hooks
- Horn
- Hourmeter

### OPTIONS AND ACCESSORIES

- Flashing light
- Travel alarm
- Working light
- Power to platform
- Biodegradable hydraulic oil
- Centralised batteries filling



**Haulotte**   
GROUP